

SD 300H

Main performance parameters (standard configuration)	
Operating weight	16.9 Ton
Rated load	5 Ton
Rated power	162 kW (217HP) / 2,000 rpm





SD 300H

MAIN PERFORMANCE FEATURES

Energy Efficient

- Faster acceleration performance : Perfect match between transmission and torque converter as well as fully use of engine power enable the whole machine to deliver faster acceleration.
- ZF automatic transmission : Smoother gear shift with ZF 4 shift transmission. Well proven and best quality transmission.
- Advanced dual-pump confluence technology : hydraulic system conduct efficient work, fully utilizing pump with this dual pump confluence technology.
- Arm Raise Kick-out and Return to dig function : greatly improve efficiency of work and reduce work intensity of operator.
- High stability : the distance between left and right wheels is the widest one in the industry, and well designed center of gravity greatly improve operation stability.
- Large steering angle make smaller turning radius : actions of whole machine more flexible.
- Large dump angle : Unloading materials more quickly and cleanly.
- Patented cooling system : cooling system designed by DISD greatly reduces the hydraulic oil and water temperature. Industry leading cooling system, offering a guarantee for continuous and uninterrupted work under high temperatures.

High Reliability

- High strength structure : The adoption of stress analysis technology from the Korean headquarters and the performance of strict quality testing ensure that all our components and parts are safe and reliable.
- The hinge pin for front operating device is 5-10mm larger than that for the industry. The pin shaft bushing uses durable materials to improve the durability of working device.
- Wear-resistant materials are used for the bucket and robust design applied upper parts of the bucket.
- All hydraulic cylinder O-rings and hydraulic hoses use high quality brand parts, increase hydraulic system reliability.
- Add engine preheating device, effectively improving the difficulty of low temperature startup in winter. At the same time change motor startup mode, and increase CCA capacity of battery.
- Adopting more outstanding anti-rust and anti-fade paint.

Design & Comfortability

- The interior of the cabin features an ergonomic design comprising a large operational space, a wide field of vision in front and behind, and a userfriendly control unit, thereby offering industry-leading comfort for operators.

Powertrain system

DISD SD300H loader uses an unique high-efficiency and low-energy consumption power matching technology, perfectly matching the powerful Weichai engines, and efficient and reliable ZF gearbox.



Engine: Weichai Steyr WD10G220E23 engine: the rated power is 162kW and the rated RPM is 2,000 rpm; after the segmenting and tuning of working conditions, the commonly used working conditions are within the segment of low fuel consumption.



Use exhaust turbine to increase pressure, therefore, torque reserve is large and the fuel consumption and engine oil consumption are low with good altitude adaptability which meet the emission standards of Tier II. The low speed of 2,000rpm + perfect power matching+dual pump confluence technology make DISD loaders more fuel efficient compared to competing enterprises under the same working condition.

Hydraulic system

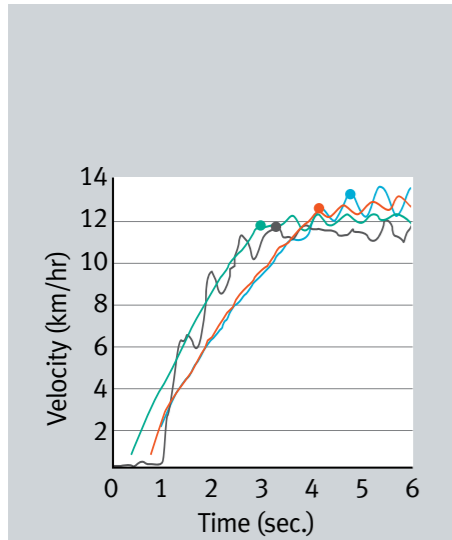

The injection pump is specially tuned on a professional test bench, so the acceleration performance of engine is improved greatly. DISD equipment starts working from the third second while other equipment is still accelerating.



Transmission box with torque converter
The ZF automatic transmission box with electro-hydraulic control is applied, and 4 forward and 3 reverse multi-gear functions can meet the needs of different working conditions. It matched perfectly with engine and the traction 14% higher than the industry average with easier shovel operations and increased efficiency.

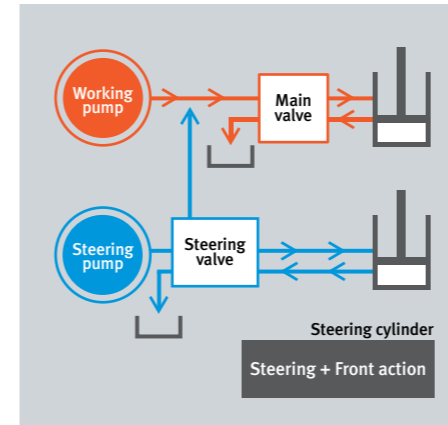

Advanced dual pump confluence technology : hydraulic systems take full advantage of power and energy and achieve the minimum hydraulic load of engine; maximize hydraulic pump efficiency.



Pilot operating system provides comfortable machine control.



Arm Raise Kick-out and Return to dig function : reduce the intensity of your work and improve working efficiency.



Equipped with international high quality Hydraulic Steering Unit which may supply the surplus hydraulic oil in the steering system to working system depends on working condition. So the energy consumption of the hydraulic system can be reduced.

Cooling system

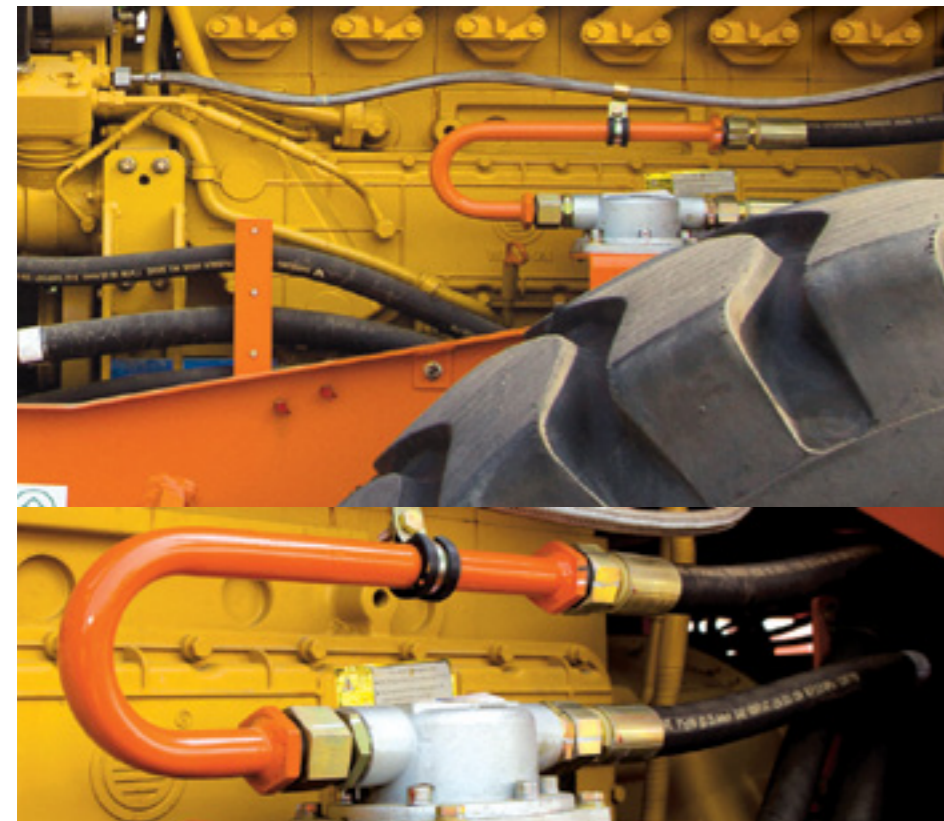
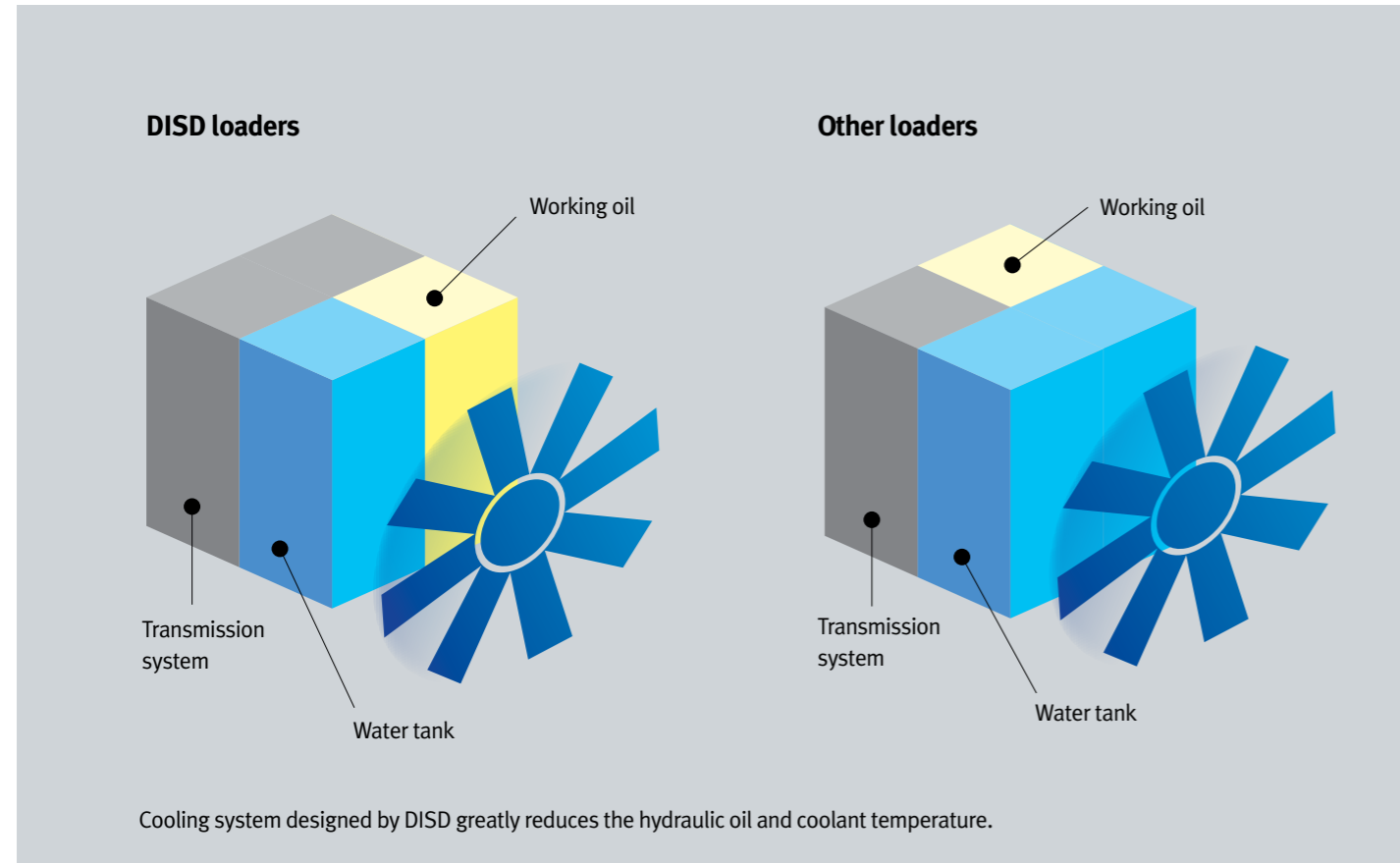

Well arranged pipe and layout help hydraulic flow and cooling. That makes more reliable machine

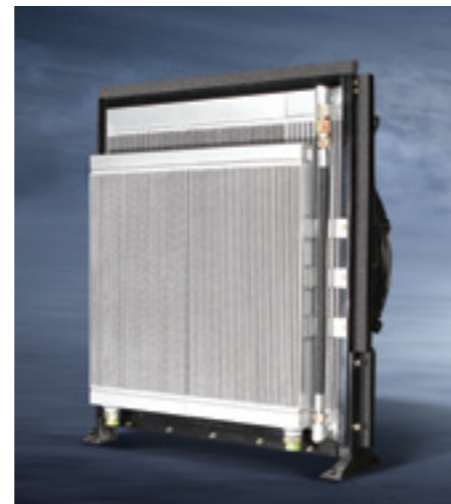

By improving the cooling system layout and materials, DISD's unique patented cooling technology greatly reduces hydraulic oil and coolant temperature during the machine's operation time, thus resolving the high temperature problem that has been hanging over the industry for many years. The machine is guaranteed not to overheat even after 24hrs of continuous work under 45°C atmospheric temperature.

Design of Whole Machine

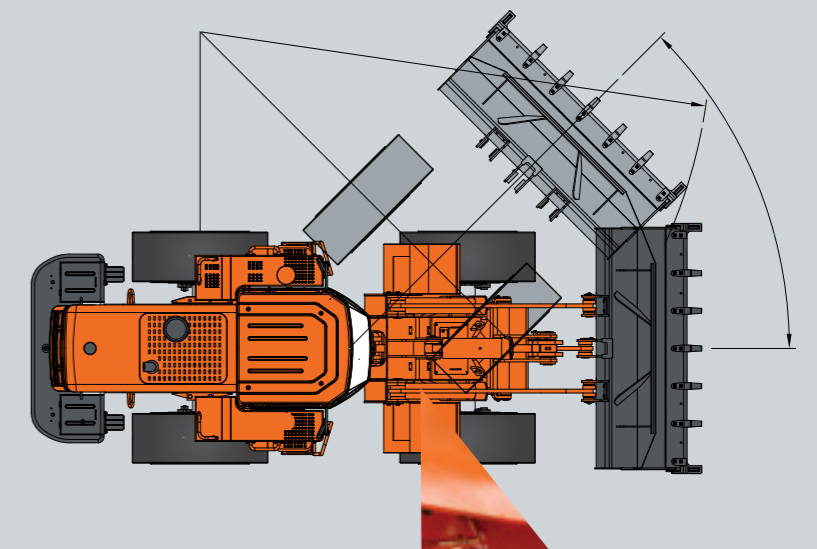

As to the design of the center hinge, the turning angle is the largest in the industry (40°); the turning radius is the shortest in long wheelbase products of the industry and equipment flexibility is the highest.



Structure parts

Through more advanced 3D design and a variety of experiments, and then after repeated verification and equipment reliability tests, greatly prolonged the service life of equipment, created higher value for customers.

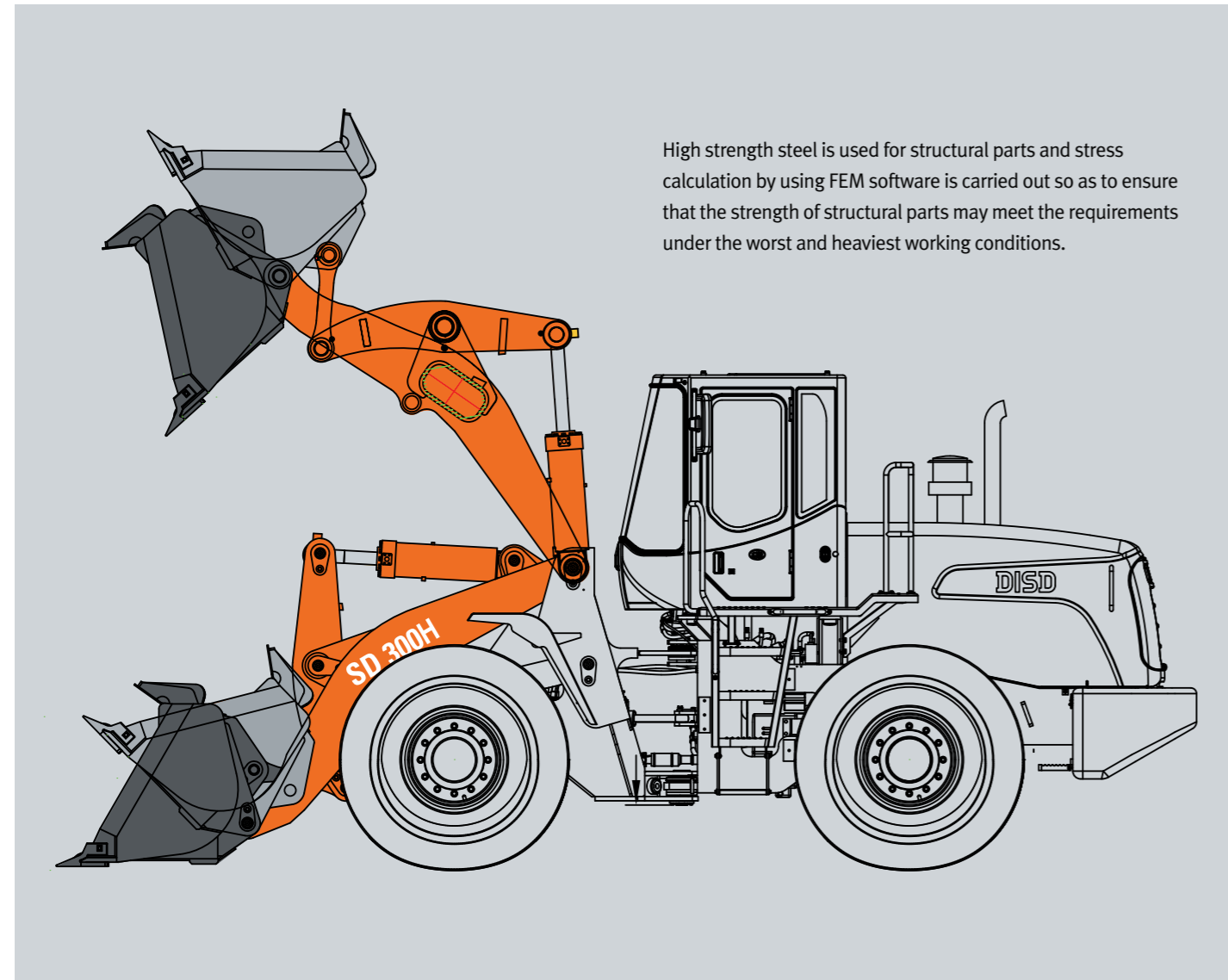

High strength steel is used for structural parts and stress calculation by using FEM software is carried out so as to ensure that the strength of structural parts may meet the requirements under the worst and heaviest working conditions.

Working device

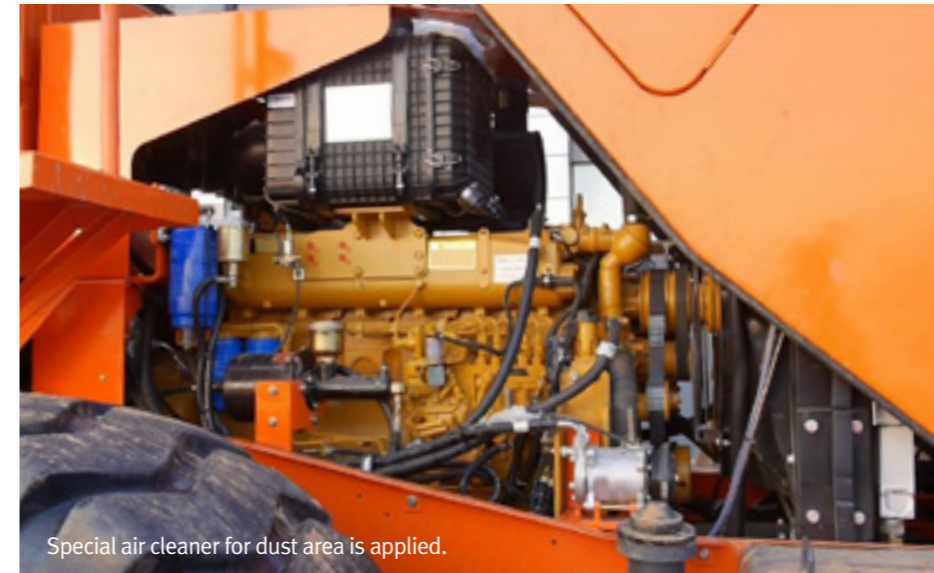

Special air cleaner for dust area is applied.

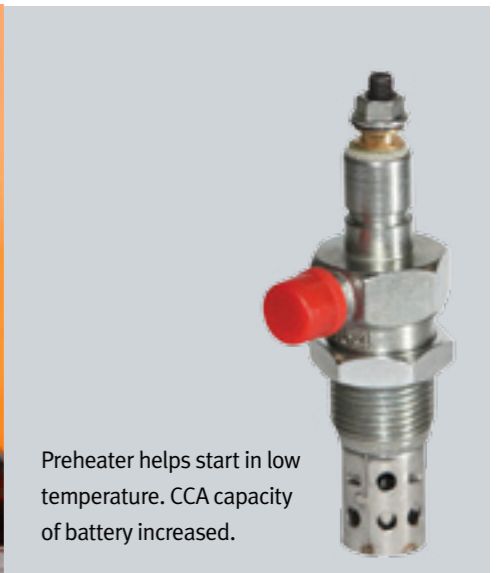

Preheater helps start in low temperature. CCA capacity of battery increased.



New pilot solid main control valve has high precision machining and perfect fretting performance which may lower inside leak and prolong the service life. A pilot filter is added specially to increase the reliability of pilot system.



CASAPPA double pump has a higher volume rate, lower pulsation, lower failure rate, higher reliability and longer service life.



All hydraulic cylinder O-rings and hydraulic hoses use high quality brand parts : reduces oil leak problems.



The diameter of the hinge pin in the 6 operating devices is 5-10mm larger than the level of the industry. High wear-resistant materials are used for pin sleeves so that the durability of working device is stronger and the residual value of second-hand equipment is higher after being coated with MoS2 and processed with a special heat treatment process.



Wear-resistant materials are used for the bucket, and robust design applied upper parts of the bucket, which may effectively prevent the deformation of the bucket caused by stones and other falling objects.



Transmission shaft: Apply reinforced transmission shaft and self-locking nuts are used as the connecting bolts of the transmission shaft so as to improve the durability of transmission system.



Parking brake button for safety.



Well desinged and arranged electronic circuit.

Cab

The interior of the cabin features an ergonomic design comprising a large operational space, a wide field of vision in front and behind, and a userfriendly control unit, thereby offering industry-leading comfort for operators.



Adjustable Steering Wheel.



Adjustable railing High backrest, deep sitting position, multi-level spring shock absorption, comfortable and luxurious seat.



The interior decoration in the cab is upscale : FRP-ABS materials are used for dash board and console and striae treatment is applied to the surface, which is high-grade and durable.



High-quality audio system MP3 + radio, and USB interface for phone charge.



Hinge Limit
DISD loader adopts a new part - the nylon hinge limit block. It has stronger durability, no noise caused by impact and reduces the driver's fatigue.



Ergonomics is used to design the inside of the cab, so the driving space is larger and the front-rear field of vision is more open. The operating device is a user-friendly design and the comfort of driving it is leading in the industry.

MAINTENANCE

Easy maintenance for more uptime

Equipment maintenance, repair and service become simpler and quicker, which may greatly improve efficiency and save costs.



The fuel tank is placed on the rear. Thick plates are applied, which may significantly reduce the rate of damages caused by collision.



Maintenance windows have been added to each side of the engine hood, thus making daily oil inspection and maintenance works quicker and more convenient.



Full Tilting of Engine Cover
With this one body engine cover, it is easy to repair engine and sub parts.



Waterproof back buzzer.



Window for convenient brake oil check.



Quickly Changeable Brake Disc
Brake disc can be replaced quickly and easily without disassembling tires, deeply shortening the maintenance time and saving time and labor cost.



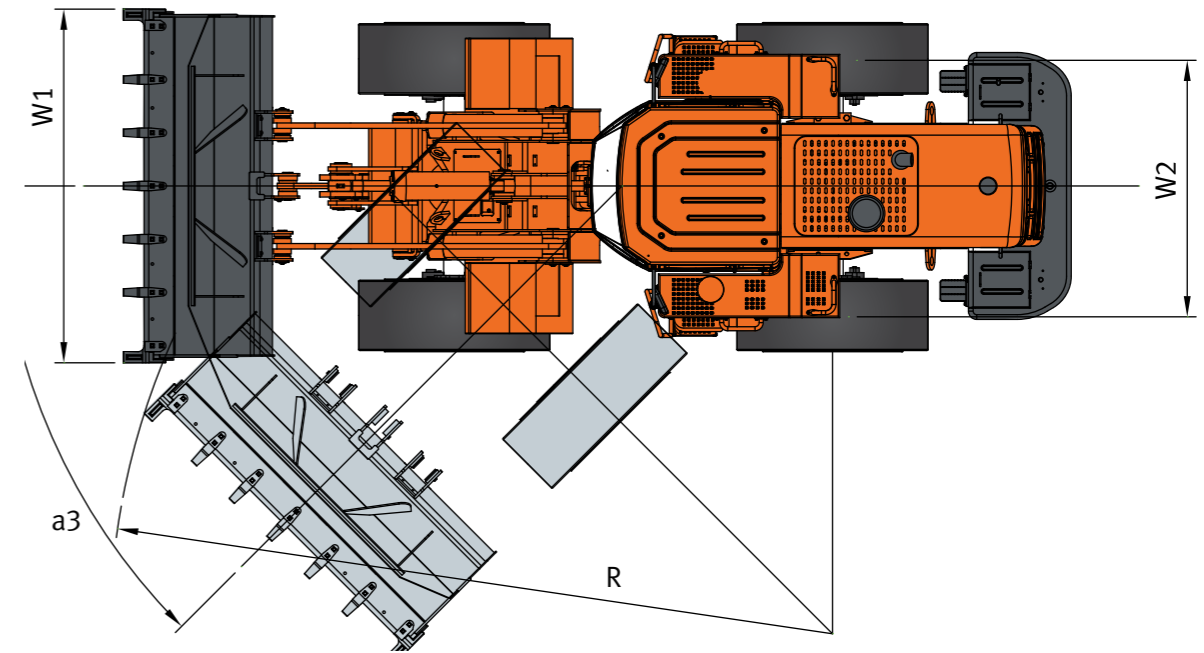
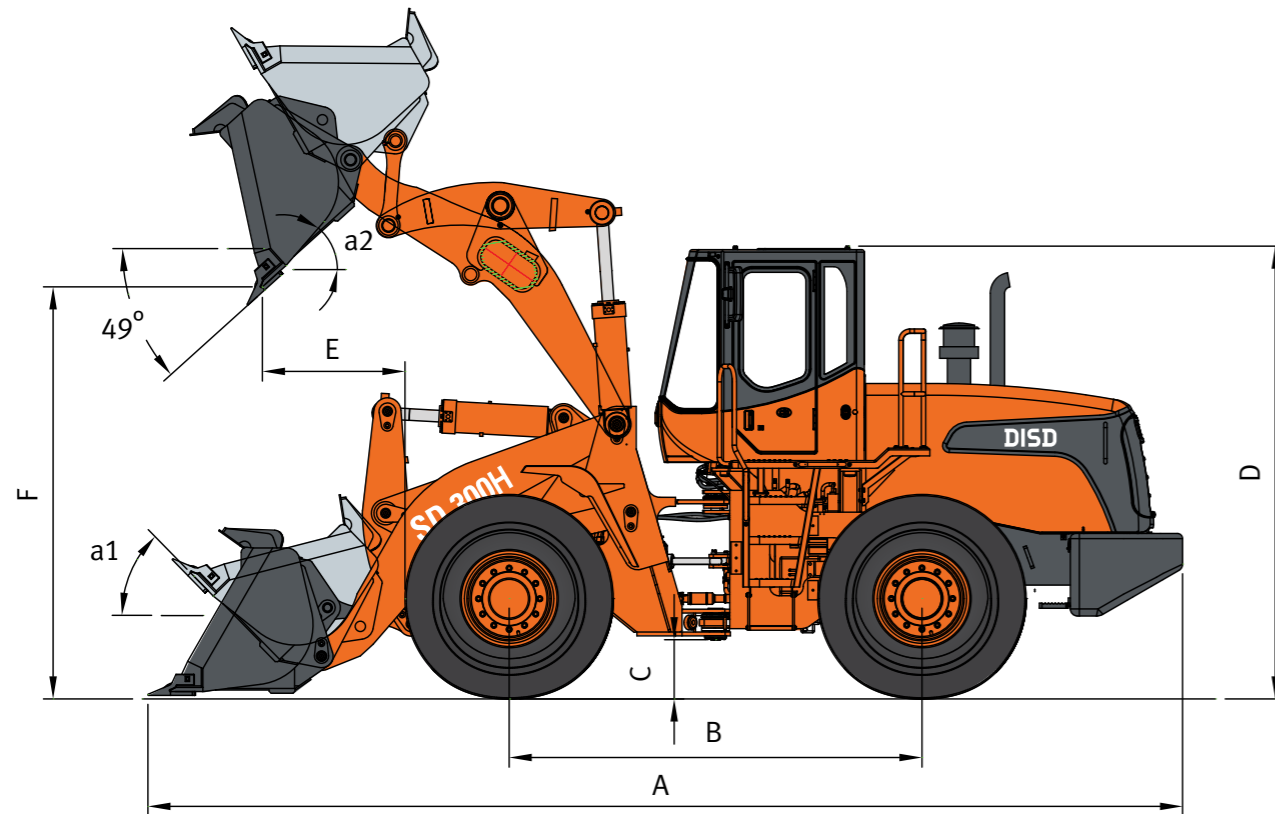

General

Bucket capacity (w/BOT)		3.0 m ³
Operating weight (ton)		16.9
Equipment L x W x H (mm)		8,020 x 2,992 x 3,450
Payload (ton)		5
Wheel base (mm)	B	3,200
Tread (mm)	W2	2,174
Min. ground clearance (mm)	C	450

Transmission system

Transmission	Electro-control hydraulic and full automatic transmission with fixed axis			
Gear	I	II	III	IV
Forward	6.3	11.4	22.7	36.5
Backward	6.3	11.5	22.4	
Drive form	Four-wheel drive			
Tyre	23.5-25-16PR			
Max tractive effort (Ton)	16.8			
Max. gradeability	30°			
Max. steering angle	40°			
Min. turning radius (mm)	6,510			

Engine

Model	Weichai Steyr Engine WD10G220E23, turbo	
Rated power, SAE J1995 Gross	162 kW (217HP) (220PS) / 2,000 rpm	
Number of cylinders x bore x stroke	6 x 126 x 130	
Displacement	9.7 ℓ	
Max. torque, SAE J1995 Gross	900 N.m / 1,300-1,500 rpm	

Working device

Bucket hinge height (mm)	4,150
Max. dump height (w/Bucket) (mm)	F 3,080
45° Dump reach (w/Bucket) (mm)	1,290
Max. breakout force (ton)	16.8
Max. dump angle	a2 49°
Max. tilt angle (on ground)	45°
Max. tilt angle (at carry)	a1 50°

Hydraulic system

Pump size (Main)	104.9 ml/rev
System pressure	170 kgf/cm ²
Total cycle time (sec)	10.4

Sound level

Sound level in Cabin	85 dB
----------------------	-------

Volume data

Fuel tank	300 ℓ
Hydraulic oil tank	250 ℓ
Engine oil	19 ℓ
Torque converter & Transmission	35 ℓ
Axle oil (Front/Rear)	27 ℓ / 27 ℓ
Hub reduction (Front 2 EA/Rear 2EA)	2EA x 5 ℓ / 2EA x 5 ℓ

Options

2.7 m ³ V-shape rock
2.7 m ³ mono tooth
2.9 m ³ cutting edge, 3.2 cutting edge
4.0 m ³ light bucket
Long boom (hinge height 4,450 mm)
Super long boom (hinge height 4,666 mm)
Heavy duty arm (hinge height 4,150)
- 3 spool control valve (2 spool control valve is standard)
- ROPS CABIN
- Attachment
Glass shading film in cab
Desert tyre

DISD

A Doosan Brand

No. 1088, Xincheng Street. Muping Economic Developing Zone
Yantai Shandong 264100 China
Tel : +86-0535-470-7431 Fax : +86-0535-470-2005



Materials and Specifications in the catalogue are subject to change without notice.